

## C1848 – 1800 lb Cube Ice Machine

### Prodigy® Modular Cube Ice Maker



Shown on BH1600SS bin.

### Features

Prodigy® cubers use **significantly less energy and water** than other cube ice machines, exceeding California and Federal energy efficiency regulations.

**AutoAlert™ indicator lights** constantly communicate about operating status and actually signal your staff when it's time to descale, sanitize, and more—making upkeep practically foolproof.

The patented **WaterSense adaptive purge control** delivers maximum reliability by reducing scale buildup for a longer time between cleanings.

**Preventative maintenance is simpler** than ever with easily-removed panels allowing clear access to internal components and a diagnostic code display insuring the right fix the first time. Reusable air filter is easily removable from the outside.

All external panel components are crafted for **optimal aesthetic appeal** through superior fit and finish.

An optional **advanced feature Smart-Board™** provides NAFEM data protocol and additional operational data that can be displayed on-screen or transmitted remotely, resulting in early alert and fast diagnosis of operating issues.

An optional **Vari-Smart™ ultrasonic ice level control** sensor allows you flexibility to program ice levels, for up to 7 days, keeping just the right amount of freshly made ice in the bin.

### 24 Hour Volume Production

Air Cooled		Remote		Water Cooled	
70°F/21°C 50°F/10°C lb/kg	Air Water	ARI 90°F/32°C 70°F/21°C lb/kg	70°F/21°C 50°F/10°C lb/kg	Air Water	ARI 90°F/32°C 70°F/21°C lb/kg
1909/868		1527/694	1828/831	1645/748	1900/864
					1710/777



### Modular Bin Options

\* Stainless Steel with Galvanized Back & Bottom.

Model Number	Dimensions W" x D" x H"	ARI Certified Bin Capacity lb/kg	Application Capacity lb/kg	Finish	Ship Weight lb/kg
BH1300BB	60 x 34 x 50	1100/499	1400/635	SS w/ GBB*	310/140
BH1300SS	60 x 34 x 50	1100/499	1400/635	SS	310/140
BH1600BB	60 x 34 x 62	1375/624	1755/796	SS w/ GBB*	370/168
BH1600SS	60 x 34 x 62	1375/624	1755/796	SS	370/168



Bin: BH1300SS

### Cube Ice



Small Cube  
7/8" x 7/8" x 3/8"  
(2.22 x 2.22 x .95 cm)

Medium Cube  
7/8" x 7/8" x 7/8"  
(2.22 x 2.22 x 2.22 cm)

Common ice form, ideal for mixed drinks.

### Warranty

- 3 years parts and labor on all components.
- 5 years parts and labor on the evaporator.
- 5 years parts on the compressor and condenser.

Warranty valid in North, South & Central America. Contact factory for warranty in other regions.

# Scotsman®

The smart choice in ice.™

# C1848 – 1800 lb Cube Ice Machine

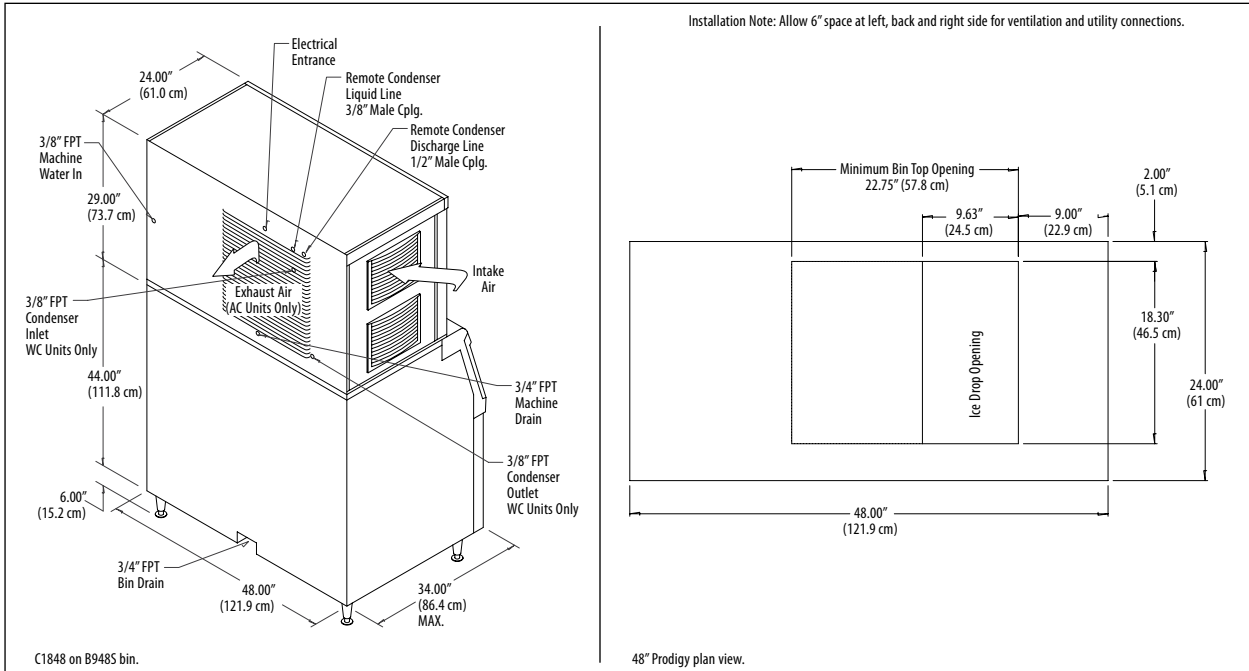

## Specifications

Model Number* <small>Cube Size: medium or small</small>	Condenser Unit	Basic Electrical Volts/Hz/Phase	Max. Fuse Size or HACR Circuit Breaker (amps)	Circuit Wires	Min. Circuit Ampacity	Energy Consumption kWh/100 lb (45.4 kg) 90°F(32°C)/70°F(21°C)	Water Usage Gallons/100 lb (liters/45.4 kg)	
							Potable 90°F(32°C)/ 70°F(21°C)	Condenser 90°F(32°C)/ 70°F(21°C)
C1848MA-32A	Air	208-230/60/1	30	2	25.5	4.9	19.3/73.2	-
C1848MR-32A	Remote	208-230/60/1	30	2	24.8	4.3	17.9/67.9	-
C1848MW-32A	Water	208-230/60/1	30	2	23.8	3.7	18.0/68.2	151.0/572.5
C1848SA-32A	Air	208-230/60/1	30	2	25.5	4.9	19.3/73.2	-
C1848SR-32A	Remote	208-230/60/1	30	2	24.8	4.3	17.9/67.9	-
C1848SW-32A	Water	208-230/60/1	30	2	23.8	3.7	18.0/68.2	151.0/572.5

\* 208-230/60/3 Voltage - Substitute "-3" in place of "-32", i.e. C1848SA-3A. = ENERGY STAR®

## All Models

Dimensions (W x D x H):  
Unit:  
48" x 24" x 29"  
(121.9 x 61.0 x 73.4 cm)

Shipping Carton:  
51.5" x 27.5" x 34"  
(130.8 x 69.9 x 86.4 cm)

Shipping Weight:  
355 lb / 161 kg

BTUs per hour:  
27,400

## Accessories

Model Number	Description
KVS	Vari-Smart™ Ice Level Control - Program ice bin levels to match ice needs.
KSB	Smart-Board™ Advanced Control - Use additional operational data for fast diagnosis.
KSB-N	Smart-Board™ Advanced Control with Network - Network capable.
ERC611-32A	Remote Condenser for C1848xR, 208-230/60/1 - Consult Remote Condenser Spec Sheet for details.
RTE10	Line set, Precharged, R-404A, 10ft.
RTE25	Line set, Precharged, R-404A, 25ft.
RTE40	Line set, Precharged, R-404A, 40ft.
RTE75	Line set, Precharged, R-404A, 75ft.

\* Scotsman recommends all ice machines have water filtration. See Scotsman Sanitation Matrix for details.

## Operating Requirements

	Minimum	Maximum
<b>Air Temperatures</b>	50°F (10°C)	100°F (38°C)
<b>Water Temperatures</b>	40°F (4.4°C)	100°F (38°C)
<b>Remote Cond. Temps</b>	-20°F (-29°C)	120°F (49°C)
<b>Water Pressures</b>	20 PSIG (1.4 bar)	80 PSIG (5.5 bar)
<b>Electrical Voltage</b>	-5%	+10%

Specifications and design are subject to change without notice.

Scotsman Ice Systems  
775 Corporate Woods Parkway  
Vernon Hills, IL 60061

1-800-SCOTSMAN  
Fax: 847-913-9844  
E-mail: [customer.service@scotsman-ice.com](mailto:customer.service@scotsman-ice.com)

[www.scotsman-ice.com](http://www.scotsman-ice.com)