

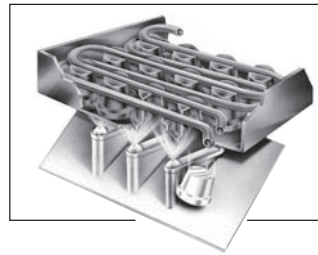

ICE one

ICE one
ICE two
ICE three



GOURMET ICE CUBE

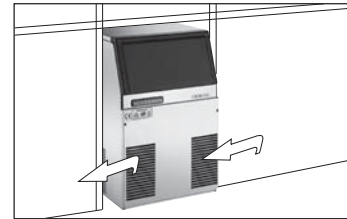
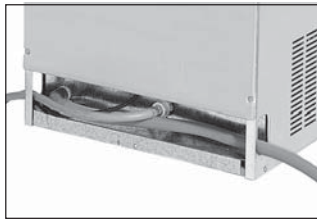
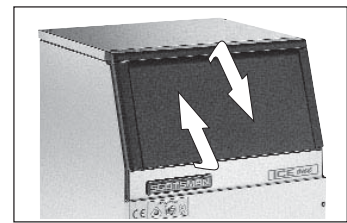

**Automatic
Gourmet-Cube
Ice Maker**

**Machine
Automatique
à Glaçons
Gourmet**

**Automatischer
Gourmetkegel-
eisbereiter**

**Màquina
Automàtica
Fabricadora
de Cubitos
Gourmet**

**Produttore
Automatico
di Ghiaccio
a Cubetti
Gourmet**

ICE ONE AS		23 51 1150	14 31 700	230/50/1	725x457 x 480	28"x18" x 19"	R 134 A
ICE ONE WS		25 55 1250	14 31 700	230/50/1	725x457 x 480	28"x18" x 19"	R 134 A

2

Years Warranty
Ans de Garantie
Jahre Garantie
Años de Garantía
Anni di Garanzia

Subject to certain limitations and exclusions
Assujettie aux limites et exclusions prescrites
Abhängig von Bestimmten Einschränkungen und Ausnahmen
Sujeta a ciertas limitaciones y exclusiones
Soggetta ad alcune limitazioni ed esclusioni



This product qualifies for the following listings:



ICE one

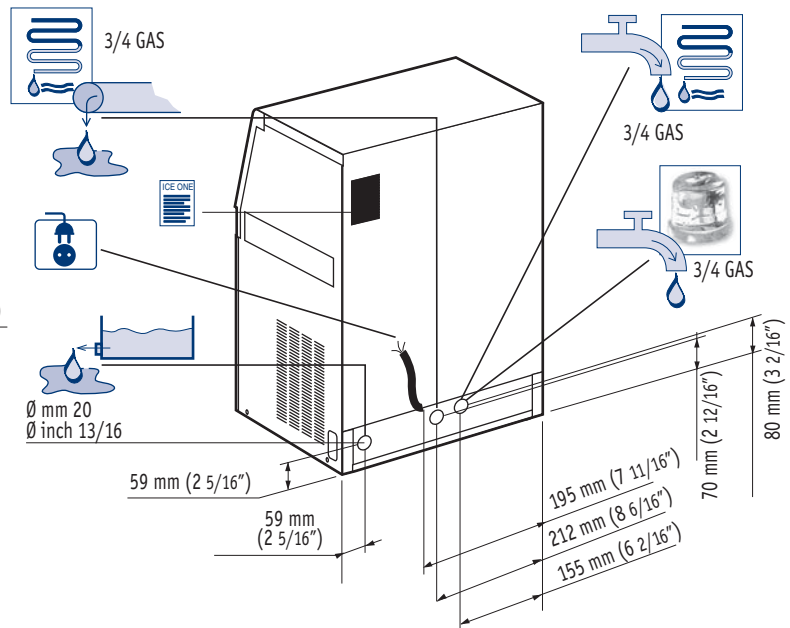
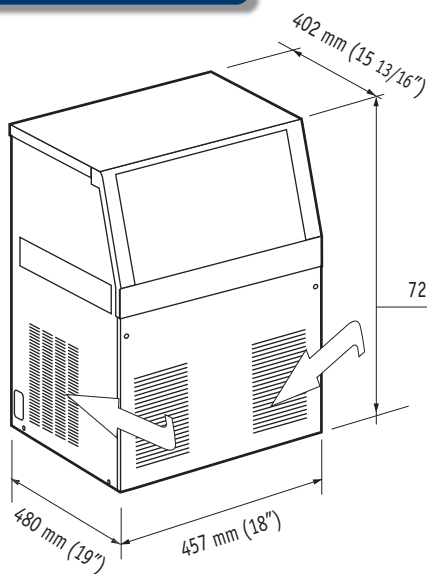

	+C° -C°	[Btu/h] [W]	[Ømm ²]	[W]	FUSE	[kWh] 24h	[L/h] [gal/h]	32°C 90°F 21°C 70°F	[kg] [lbs]	[kg] [lbs]
ICE ONE AS		2287 670	3x1	340	10 A	6.5	4.6 1.2		39 86	46 101.2
ICE ONE WS		2287 670	3x1	340	10 A	6.5	12 3.1		39 86	46 101.2

ICE ONE AIR



°F	50°	60°	70°	90°	
°C	10°	15°	21°	32°	
10°	51	48	46	42	lbs
50°	23	22	21	19	kg
21°	48	46	44	40	lbs
70°	22	21	20	18	kg
32°	44	42	40	35	lbs
90°	20	19	18	16	kg
38°	42	40	37	33	lbs
100	19	18	17	15	kg



Machine requires voltage indicated on rating name plate. Failures caused by improper voltage are not considered factory defects. Scotsman products are not designed for outdoor installation. Extended periods of operation at temperatures exceeding the above limitations constitutes misuse under the terms of Scotsman Limited Warranty, resulting in a loss.

ICE ONE WATER



°F	50°	60°	70°	90°	
°C	10°	15°	21°	32°	
10°	55	53	51	46	lbs
50°	25	24	23	21	kg
21°	48	46	44	40	lbs
70°	22	21	20	18	kg
32°	44	42	40	35	lbs
90°	20	19	18	16	kg
38°	42	40	37	33	lbs
100	19	18	17	15	kg



La machine doit être raccordée conformément au voltage indiqué sur la plaque signalétique. Les éventuels dégâts causés par un non respect de cette consigne ne peuvent être considérés comme des défauts de fabrication. Les machines à glace Scotsman ne sont pas conçues pour être utilisées à l'extérieur. Le fonctionnement prolongé à des températures supérieures ou inférieures aux limites ci-dessus sont considérées comme une mauvaise utilisation dans le cadre de la garantie Scotsman.

Der Eisbereiter benötigt eine Stromspannung gemäß Geräte-Typenschild. Störungen oder Ausfälle, durch den Betrieb mit falscher Stromspannung sind keine Fabrikationsfehler und fallen nicht unter Garantie. Scotsman Eisbereiter sind nicht für die Installation im Freien geeignet. Der längere Betrieb bei Temperaturen über den obigen Grenzwerten ist eine falsche Anwendung und bedeutet den Verlust der Garantieleistung.

Los requerimientos eléctricos de la máquina están indicados en la placa de características. Los daños causados por voltajes inadecuados no son considerados defectos de fábrica. La máquinas de hielo Scotsman, no están diseñadas para trabajar a la intemperie. Largos periodos de funcionamiento a temperaturas que excedan de las limitaciones indicadas, constituyen maltrato de acuerdo con las observaciones de Scotsman.

La macchina richiede il voltaggio indicato sulla targhetta di identificazione. Danni causati da voltaggi diversi non sono considerati difetti di produzione. I prodotti Scotsman non vanno utilizzati all'aperto. Un prolungato periodo di utilizzo al di fuori delle temperature indicate non è consentito e causa l'automatico decadere della garanzia.



Minimum

10°C (50°F)

5°C (41°F)

-10%

1 BAR
14 psi

Maximum

40°C (104°F)

35°C (95°F)

+10%

5 BAR
70 psi

Scotsman® Ice Systems

CONTACT POINTS:

Europe
Scotsman Europe-Frimont S.p.A.
Ph/Fax +39-0293960208 / 0293960201
scotsman.europe@frimont.it
Paolo Moro

Middle East & N. Africa
Scotsman-Frimont Regional Office (ME&NA)
Ph/Fax +97-16 5262944 / 165262946
m.dawood@frimont.ae
fernando.m@frimont.ae

Asia and Pacific
Scotsman Industries (S) PTE. L.T.D.
Ph/Fax +65-67385393 / 67381959
scotsman@scotsman.com.sg
Andrea Tronci

South Africa
Scotsman SA (Pty) Ltd - Ice Systems (Pty) Ltd
Ph +27-0105900609 / 0877200245/6/7/8
Fax: +27-118264123 / 0866340803
stuart@scotsmansa.co.za - jennifer@scotsman.co.za

India
Scotsman Group India
Ph/Fax : +91-1244002459 / direct 9560072459
david.owen@scotsman.com.sg

Spain
Scotsman España, S.L.U. c/ Galapagar, 12
Ph/Fax +34-911109796 / 916337423
scotsman@scotsman-espana.es
Daniel Doblado

China
Scotsman Ice Systems (Shanghai)
Ph/Fax : +86-2161313200 / 2161313330
scotsman.shanghai@scotsman-china.com
Andrew Clayton