

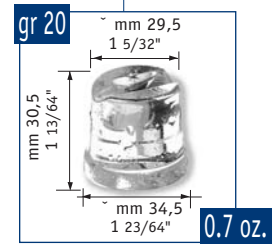

ICE two

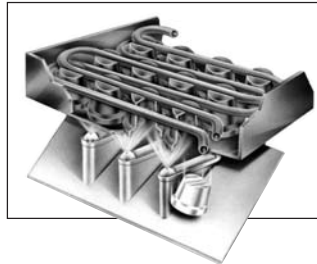

GOURMET ICE CUBE

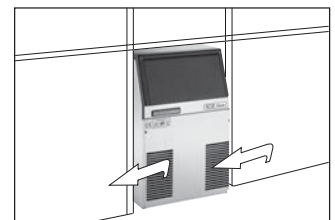

SS AISI 304

**Automatic
Gourmet-Cube
Ice Maker**

**Machine
Automatique
à Glaçons
Gourmet**

**Automatischer
Gourmetkegel-
eisbereiter**

**Màquina
Automàtica
Fabricadora
de Cubitos
Gourmet**

**Produttore
Automatico
di Ghiaccio
a Cubetti
Gourmet**

Model	Fan/Compressor	24h		Capacity	Voltage/Phase	Dimensions (mm)	Dimensions (inches)	Ice Thickness (mm)	Ice Thickness (inches)	Warranty			
		[kg] [lbs]	Nº								[kg] [lbs]	Nº	
ICE TWO AS	☪	31 68	1550	28 62	1400	14 31	700	230/50/1	457x522x738	18 1/8 x 20 1/8 x 29 1/8	H=738+120	29 1/8 + 4 1/8	R 134 a
ICE TWO WS	☪	30 66	1500	28 62	1400	14 31	700	230/50/1	457x522x738	18 1/8 x 20 1/8 x 29 1/8	H=738+120	29 1/8 + 4 1/8	R 134 a

*Estimated number of medium size gourmet cubes.
Standard legs 120 mm high included.
Leg extension 60 mm high available upon request (code no. KITLEGSEXT000).

www.scotsman-ice.com
www.scotsman-ice.it

2

Years Warranty
Ans de Garantie
Jahre Garantie
Anni di Garanzia

Subject to certain limitations and exclusions
Assujettie aux limites et exclusions prescrites
Abhängig von Bestimmten Einschränkungen und Ausnahmen
Sujeta a algunas limitaciones y exclusiones
Soggetta ad alcune limitazioni ed esclusioni



This product qualifies for the following listings:



Models and specifications are subject to change without notice - Les modeles et les caracteristiques des appareils peuvent être changés sans préavis - Wir behalten das Recht vor jederzeit Änderungen der Modelle und der technischen Angaben vorzunehmen. Los modelos y las características pueden ser modificados en cualquier momento sin previo aviso - I modelli e le specifiche possono essere cambiate in qualunque momento senza preavviso

ICE two

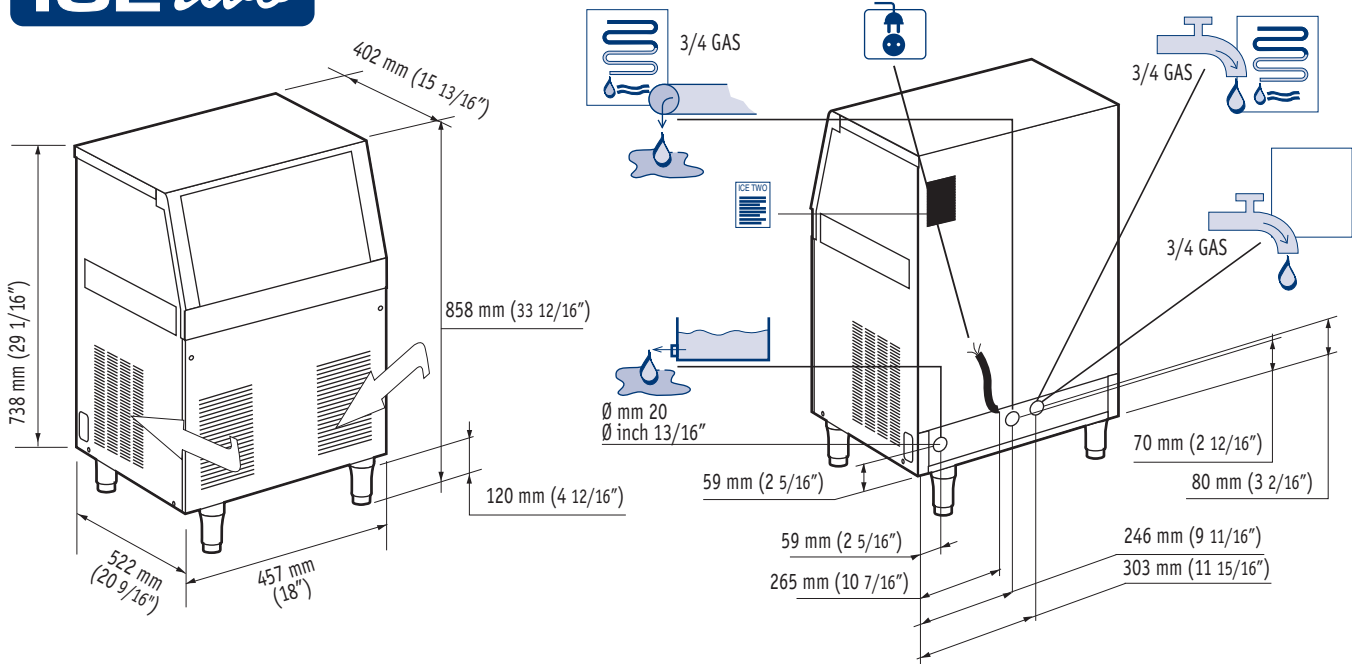

		[Btu/h] [W]	[Ømm ²]	[W]	FUSE [A]	[kWh]	[l/h] [gal/h]	[kg] [lbs]	[kg] [lbs]	[kg] [lbs]	[kg] [lbs]	[kg] [lbs]	
ICE TWO AS		2290 670	3x1	360	10	7	4.4 1.2	42 92	48 106				
ICE TWO WS		2290 670	3x1	360	10	7	25.2 7.0	42 92	48 106				

ICE TWO AIR COOLED

ICE TWO WATER COOLED

C/F	C/F				kg
	50	60	70	90	
10	31	30	29	27	kg
50	68	66	64	59	lbs
21	29	28	27	25	kg
70	64	62	59.5	55	lbs
32	25	24	23	21	kg
90	55	52	51	46	lbs
38	23	22	21	19	kg
100	51	48	46	46	lbs

C/F	C/F				kg
	50	60	70	90	
10	30	29	28	26	kg
50	66	64	62	57	lbs
21	29	28	27	25	kg
70	64	62	59	55	lbs
32	27	26	25	23	kg
90	59	57	55	51	lbs
38	25.5	24.5	23.5	21.5	kg
100	56	54	52	47	lbs

Minimum	Maximum
10°C (50°F)	40°C (104°F)
5°C (41°F)	35°C (95°F)
-10%	+10%
1 BAR 14 psi	5 BAR 70 psi

Machine requires voltage indicated on rating name plate. Failures caused by improper voltage are not considered factory defects. Scotsman products are not designed for outdoor installation. Extended periods of operation at temperatures exceeding the above limitations constitutes misuse under the terms of Scotsman Limited Warranty, resulting in a loss.

La machine doit être raccordée conformément au voltage indiqué sur la plaque signalétique. Les éventuels dégâts causés par un non respect de cette consigne ne peuvent être considérés comme des défauts de fabrication. Les machines à glace Scotsman ne sont pas conçues pour être utilisées à l'extérieur. Le fonctionnement prolongé à des températures supérieures ou inférieures aux limites ci-dessus sont considérées comme une mauvaise utilisation dans le cadre de la garantie Scotsman.

Der Eisbereiter benötigt eine Stromspannung gemäß Geräte-Typenschild. Störungen oder Ausfälle, durch den Betrieb mit falscher Stromspannung sind keine Fabrikationsfehler und fallen nicht unter Garantie. Scotsman Eisbereiter sind nicht für die Installation im Freien geeignet. Der längere Betrieb bei Temperaturen über den obigen Grenzwerten ist eine falsche Anwendung und bedeutet den Verlust der Garantieleistung.

Los requerimientos eléctricos de la máquina están indicados en la placa de características. Los daños causados por voltajes inadecuados no son considerados defectos de fábrica. La máquinas de hielo Scotsman, no están diseñadas para trabajar a la intemperie. Largos periodos de funcionamiento a temperaturas que excedan de las limitaciones indicadas, constituyen maltrato de acuerdo con las observaciones de Scotsman.

La macchina richiede il voltaggio indicato sulla targhetta di identificazione. Danni causati da voltaggi diversi non sono considerati difetti di produzione. I prodotti Scotsman non vanno utilizzati all'aperto. Un prolungato periodo di utilizzo al di fuori delle temperature indicate non è consentito e causa l'automatico decadere della garanzia.

Scotsman
Ice Systems

CONTACT POINTS:

Europe
Scotsman Europe-Frimont S.p.A.
Ph/Fax +39-0293960208 / 0293960201
scotsman.europe@frimont.it
Paolo Moro

Middle East & N. Africa
Scotsman-Frimont Regional Office (ME&A)
Ph/Fax +97-16 5262944 / 165262946
m.dawood@frimont.ae
fernando.m@frimont.ae

Asia and Pacific
Scotsman Industries (S) PTE. L.T.D.
Ph/Fax +65-67385393 / 67381959
scotsman@scotsman.com.sg
Andrea Tronci

South Africa
Scotsman SA (Pty) Ltd - Ice Systems (Pty) Ltd
Ph +27-0105900609 / 0877200245/6/7/8
Fax: +27-118264123 / 0866340803
stuart@scotsmansa.co.za - jennifer@scotsman.co.za

India
Scotsman Group India
Ph/Fax : +91-1244002459 / direct 9560072459
david.owen@scotsman.com.sg

Spain
Scotsman España, S.L.U. c/ Galapagar, 12
Ph/Fax +34-911109796 / 916337423
scotsman@scotsman-espana.es
Daniel Doblado

China
Scotsman Ice Systems (Shanghai)
Ph/Fax : +86-2161313200 / 2161313330
scotsman.shanghai@scotsman-china.com
Andrew Clayton