

- Full stainless exterior!
- Non-corroding polyethylene liner!
- All-polyethylene cart for added durability!



Model ITS1350SG-60 (with optional Totes ice carriers in cart)

Elevated ice storage bins and castered cart systems. Cart slides into bay below bin for convenient, gravity-fed loading. Widths from 31" (788 mm) to 90" (2286 mm) and storage capacities from 500 lbs (227 kg) to 3250 lbs (1474 kg) of ice, excluding carts. Each cart stores an additional 240 lbs (109 kg) of ice, 150 lbs (68 kg) when used with optional Totes™ ice carriers. Full stainless bin and base exterior standard.

#### Labor-saving design increases convenience and safety

- Gravity loading ice saves time, eliminates shoveling
- Castered cart rolls easily, quickly to area of use
- Optional Totes ice carriers allow safe, easy ice distribution in displays, salad bars, ice dispensers

#### All-polyethylene cart provides a better way to move ice

- Durable, easy-to-clean polyethylene eliminates dents, scratches
- Holds 240 lbs (109 kg) without optional Totes ice carriers, 150 lbs (68 kg) with Totes ice carriers
- Oversized wheels make maneuvering easy
- Cart drains to bin drain system when parked in bay

#### Totes ice carriers simplify ice distribution

- Six rugged polyethylene Totes ice carriers nest in cart
- Eliminates need to shovel ice from cart
- Slim design fits easily below breath protectors

#### Other quality construction features

- Single, reversible drain connection
- Durable polyethylene lift door with PowerHinge™ door hinge on ITS700-31, inspection window on ITS500-31
- Stainless tops custom-cut for specific icemaker(s)

#### Accessories

- Totes ice carriers (set of 6, one set per cart) (item# ABICETOTP)
- Additional ice transport cart(s)
- Drain pan (required for some Vogt and Howe icemakers; consult factory)
- Center partition for 2-bay systems; off-set partition for 3-bay systems
- Plastic shovel (item# ABICSHOVEL)
- Ice paddle and hanging bracket (item# ABICEPADDL)



JOB: \_\_\_\_\_

ITEM: \_\_\_\_\_

U.S. Patents 5,211,030 & 5,797,514

**Front View ITS700SG-31**  
(without cart in bay)  
ITS500NS has sliding window only

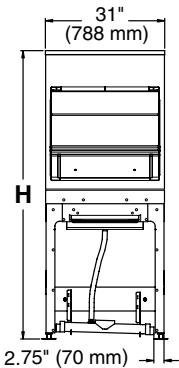

**Front View ITS1350SG-60**  
(without carts in bays)  
ITS2250SG has sliding window at top of bin

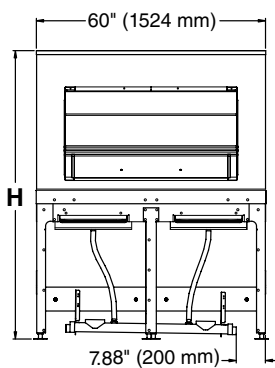

**Front View – ITS3250SG-90**  
(without carts in bays)  
ITS1700SG has no sliding windows

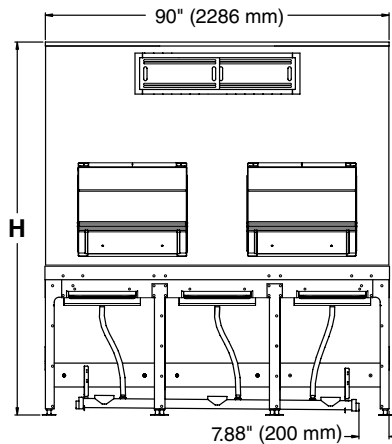

**All Models**  
(shown without cart in bay)

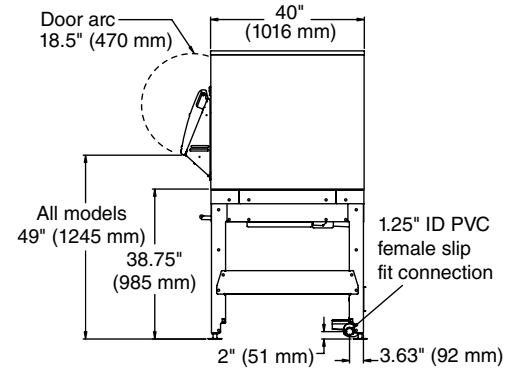

**General notes**

- Clearance required to pull cart from bay – minimum 48" (1220 mm), optimal 54" (1372 mm)
- Follett recommends installation of a floor drain with grate with all ice storage bins
- Drain connection is reversible to exit at left or right side of unit

**Front View Totes Ice Carrier**

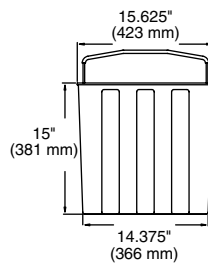

**Side View Totes Ice Carrier**



**Front View Cart**

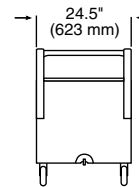

**Side View Cart**

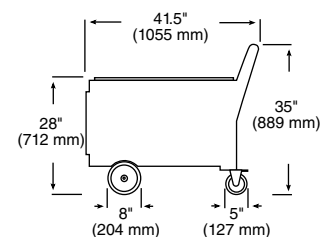

Model Number	Cubic Volume cu ft (m)	Max. Bin Cap. lb (kg) <sup>1</sup>	Max. Cap. with Carts lb (kg) <sup>1,2</sup>	No. Carts	Width in (mm)	Depth in (mm) <sup>3,4</sup>	Depth with Door in (mm) <sup>3,4</sup>	Height (H) with Legs in (mm) <sup>5</sup>	Required Access in (mm) <sup>3</sup>	Approximate Ship Wt. lb (kg) <sup>4</sup>
ITS500NS-31	12.7 (0.36)	382 ( 174)	622 ( 283)	1	31 ( 788)	40 (1016)	40 (1016)	60 (1524)	32 ( 813)	371 (169)
ITS700SG-31	21.7 (0.61)	652 ( 296)	892 ( 405)	1	31 ( 788)	40 (1016)	48 (1220)	75 (1905)	32 ( 813)	398 (181)
ITS1350SG-60	44.2 (1.25)	1327 ( 602)	1567 ( 711)	2	60 (1524)	40 (1016)	48 (1220)	75 (1905)	41 (1042)	712 (323)
ITS2250SG-60	71.1 (2.01)	2133 ( 968)	2373 (1077)	2	60 (1524)	40 (1016)	48 (1220)	97 (2464)	41 (1042)	822 (373)
ITS1700SG-90	58.2 (1.65)	1716 ( 779)	1986 ( 901)	3	90 (2286)	40 (1016)	48 (1220)	70 (1778)	41 (1042)	978 (444)
ITS3250SG-90	108.5 (3.07)	3255 (1477)	3495 (1586)	3	90 (2286)	40 (1016)	48 (1220)	97 (2464)	41 (1042)	1145 (519)

- Notes:**
- 1 Computed on cubic volume of bin. Does not reflect cart capacity or voids that can occur due to pyramiding.
  - 2 Each cart holds 240 lbs (109 kg) without optional Totes ice carriers, 150 lbs (68 kg) with Totes ice carriers.
  - 3 Required clearance for installation access through doors (may require removal of door assembly). Door assemblies remove easily (4 screws) if necessary for installation access.
  - 4 Add 2" (51 mm) to depth and 10 lbs (4.5 kg) to shipping weight when drain pan accessory used.
  - 5 Special top required for icemakers weighing more than 1000 lbs (454 kg). Add 2.125" (54 mm) to height. Contact factory.

**Specifications**

Follett® ice transport system to be model \_\_\_\_\_ equipped with Follett ice transport cart(s). Elevated bin to hold approximately \_\_\_\_\_ lbs (kg) of ice. Exterior of bin and base to be full stainless steel. All bins (except ITS500NS) to have polyethylene snout, polyethylene lift door with PowerHinge door hinge, and SmartGATE ice shield. Stainless steel bin top to be custom cut for icemaker(s) to be used. Bin liner walls to be of non-corroding polyethylene and insulated with non-CFC foam polyurethane. Bin hopper to be of polyethylene with extra large opening(s) to facilitate ice flow. Base to have built-in drains for bins and carts, and insulated drain troughs, shutter door, and drain to minimize condensation. Cart(s) to be of insulated one-piece molded polyethylene, with plastic lid, four heavy-duty casters (two swivel with one step-on lock and two non-swivel). Carts and optional Totes ice carriers to store below bin when not in use and to drain when positioned in bay. All models to have adjustable flanged feet. All models to have a paddle and be NSF-listed.

PowerHinge and Totes are trademarks of Follett Corporation.  
Follett and SmartGATE are registered trademarks of Follett Corporation, registered in the US.  
Follett reserves the right to change specifications at any time without obligation. Certifications may vary depending on country of origin.